



Ocean energy solutions from SKF

Improving reliability, availability and maintainability of tidal and wave machines



The Power of Knowledge Engineering

Tap into an ocean of



renewable energy

Becoming competitive is critical

For long-term viability of the ocean energy sector, reducing the cost of energy (COE) to a level competitive with offshore wind and other traditional power generation methods is absolutely key. Currently, incentives such as Renewable Obligation Certificates (ROCS) are available to help create a level playing field with more established power generation methods. However, ROCS will close to new generation in 2017, which will create greater uncertainty in the industry and a need for more self-reliance. Without a doubt, reducing total cost of ownership throughout the life cycle can have a huge impact on the cost of energy. And given the harsh environment in which tidal and wave machines operate, asset reliability, availability and maintainability are key factors that will influence the future success of the industry. SKF can help.

Overcome ocean energy challenges with the power of SKF knowledge engineering

SKF has many decades of experience working with the wind, marine, hydroelectric and offshore oil and gas industries around the world. SKF is now using the technical knowledge and innovative skill from these synergistic industries to address ocean energy challenges.

With its base in Scotland, our Ocean Energy team works collaboratively with prototype device developers and sub-component suppliers, helping them to design in reliability at an early stage. Our efforts help to ensure they meet their future availability and power generation targets. We also help optimize their maintenance strategy and take maintainability issues into consideration, recognizing the harsh and inaccessible environment in which ocean energy equipment is required to operate.

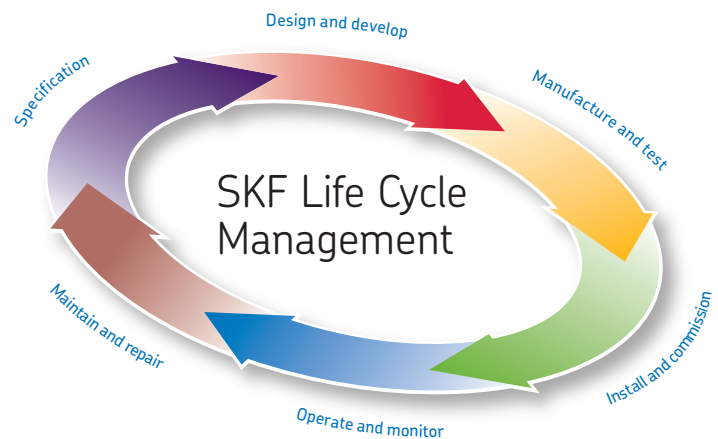

Reduce total cost of ownership through SKF Life Cycle Management

SKF adopts a Life Cycle Management approach to help our customers reduce total cost of ownership (TCO). Reliability, availability and maintainability are vital factors that require extensive consideration at the prototype design stage in order to maximise profitability in the operation phase.

Solutions beyond bearings

With our extensive portfolio of bearings, seals, lubrication systems, services and mechatronics, SKF has the capability to meet the industry's technological challenges and requirements. We can provide standard products that can be customized to individual requirements, and combine these to create multi-platform solutions /holistic systems to meet specific technical needs.

*www.theworldwater.org

SKF solutions for the tidal energy sector

Reduce downtime with SKF Condition Monitoring

SKF provides condition monitoring and reliability management services from our Remote Diagnostic Centres around the world. Our condition monitoring products and services for the offshore oil and gas, marine and the wind energy sectors can be utilized to great effect in the emerging tidal industry.

For example, SKF WindCon is a proactive condition monitoring solution that enables wind farms to extend turbine maintenance intervals, reduce unplanned downtime, predict remaining turbine service life, and decrease operating costs per kWh. The system monitors component conditions in real time, enabling maintenance decisions to be based on actual machine conditions. SKF WindCon can interconnect with all key turbine systems and continuously monitor single units or entire farms from afar using our WebCon software.

A similar system is available for monitoring the condition of marine azimuthing and tunnel thrusters. The system provides the user with an early indication of developing faults, improving maintenance planning. The system also allows the extension of class survey intervals, reducing the need for dry docking; the thruster is inspected only when the system indicates deterioration.

Over time, our service teams build a comprehensive database of exceptions and detected faults. Analyzing the historical database allows us to identify and quantify trends of poor reliability in machines/components. SKF is then able to feed this information back to original equipment manufacturers and work collaboratively with them to help improve machine design.

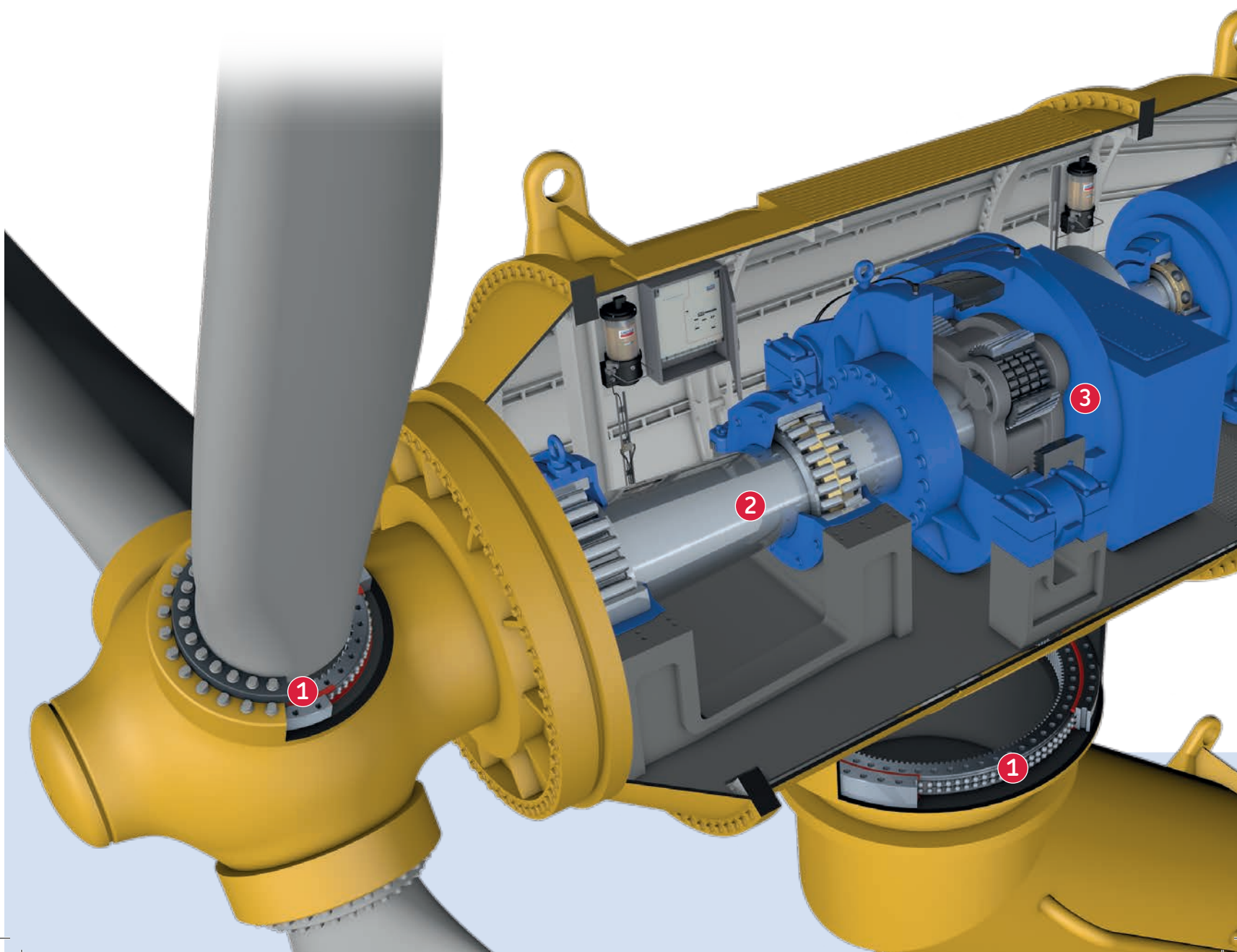

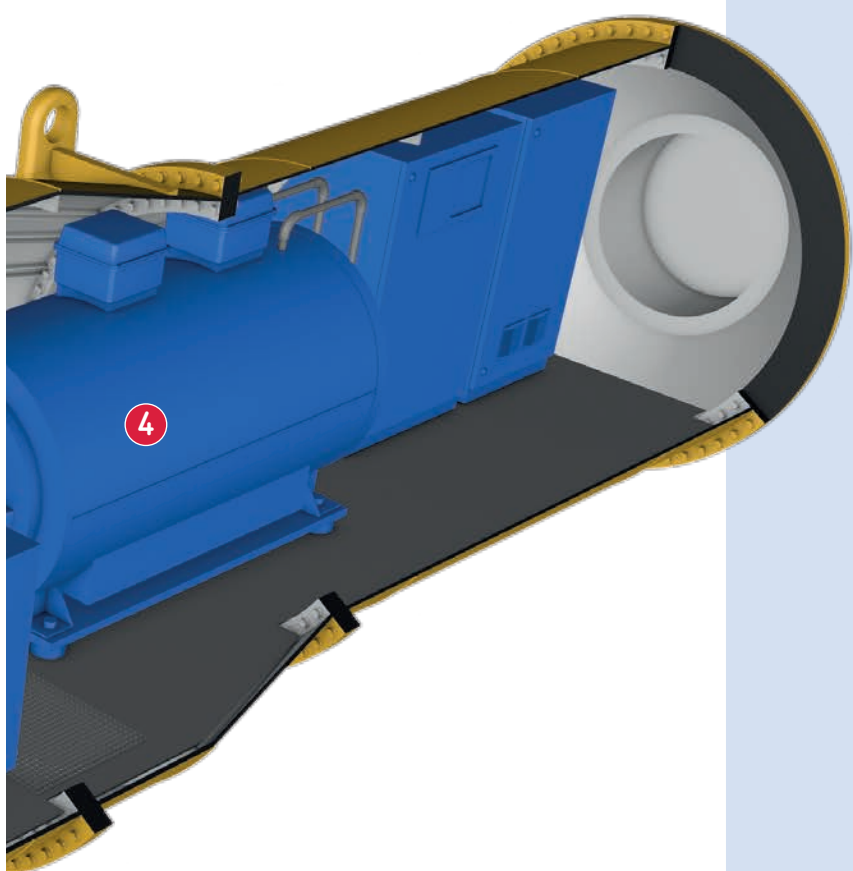

1 Pitch and yaw: Increase reliability with SKF

SKF High Endurance Slewing Bearings

The operational challenges for tidal steam turbines should not be underestimated.

Long-term exposure to the sea water environment and harsh weather conditions, along with high energy density and load conditions, presents a significant engineering and technological challenge. SKF has developed an innovative slewing bearing design with enhanced sealing capabilities and redesigned internal geometry to meet this need. The SKF High Endurance Slewing Bearing offers increased resistance to harsh environmental conditions to improve reliability and performance and extend bearing service life.

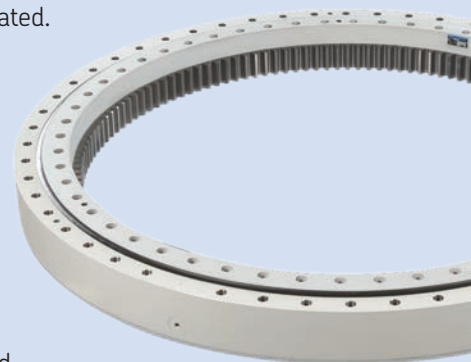

SKF spherical plain bearings

SKF spherical plain bearings are ideal for applications with misalignment, oscillation, tilting or high static and alternating loads. Because they are self-aligning, spherical plain bearings eliminate premature bearing wear caused by severe loading combined with misalignment. Our virtually maintenance-free designs are particularly valuable where there are constant, pulsating and alternating loads in the radial or axial direction, or where relubrication is not possible. SKF spherical plain bearings can also be provided with special tribologically optimized coatings to improve bearing life under unexpected, contaminated conditions. This application, therefore, addresses some key technical challenges arising from long-term exposure to the marine environment.

Actuation devices for blade pitch systems

SKF also provides a range of reliable and proven electromechanical cylinders with load capacity suitable for blade pitch systems on tidal turbines.

Designed to satisfy the most demanding application requirements, SKF actuation systems utilize linear and rotary actuators as well as control units.

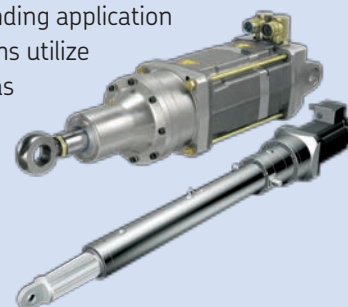

SKF solutions for the tidal energy sector

2 Main shaft: Integrated solutions for reliable performance, simplified installation and maintenance

The SKF self-aligning bearing solution



The SKF self-aligning bearing solution for turbine main shafts features a spherical roller bearing in the locating position and a CARB toroidal roller bearing in the non-locating position. This combination offers a very high load carrying capacity in a smaller, lighter housing. It also eliminates the problem of induced axial loads, offers improved reliability and at the same time enabling the cross-section of the bearing to be smaller than would be possible with conventional arrangements.

SKF Nautilus



SKF has created the next generation of SKF Nautilus bearing solutions. Expanded and improved using knowledge gained from many designs equipped with SKF Nautilus and developed in cooperation with turbine manufacturers and design consultants, these new solutions offer updated, versatile and integrated features to meet the industry's demands. The expanded range of SKF Nautilus solutions provides designers with the freedom to develop a wide variety of turbines: with gearboxes or directly driven; with outer or inner ring rotation; mounted on shafts or directly bolted onto the surrounding structure. You now have more choices than ever before.

Housings

Customized bearing housings for main shaft applications can be modified to fit the frame and shaft dimensions. The housing can be equipped with different sealing arrangements for enhanced bearing protection, long service life and reliable operation.



Couplings: High precision, quick and simplified mounting

The SKF OKCK hydraulic coupling is designed to fit within limited space and is mounted/dismounted easily and quickly using oil power – no need for loud and vibrating pneumatic wrenches. Accuracy is higher than mechanical couplings and it is designed to create controlled high pressure against the shafts without leaving any tooling permanently in place. Mounting and dismounting is also four times faster compared to mechanical couplings and can be done by one person. Factory mounting and dismounting times are each less than half an hour. The same is true for on-site mounting. Using a high friction coating on the intermediate sleeve between the main shaft and the tube-shaped input shaft of the gearbox, SKF's new OKCKX coupling offers further enhancements in capability. These include reduced cost and improved torque capacity resulting from the slimmer design, and elimination of fretting corrosion between the shafts.

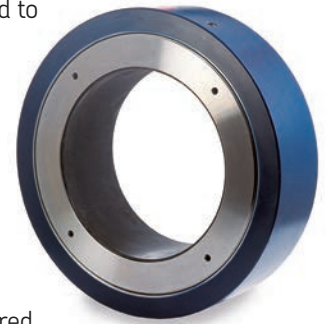

Couplings: Supergrip bolts

SKF's Supergrip bolts represent a "quantum leap" in improving the technology of connecting rotating flange couplings. They are much faster and easier to install and remove compared to traditional bolt systems, therefore reducing maintenance cost and downtime. When you connect your couplings with supergrip bolts, there is no uncertainty about the length of downtime for removing the bolts. No worry about whether the bolts have jammed or seized in the holes. You know that once the tension and expansion pressure have been released, each bolt will slide out as easily as it went in.



High performance coupling – friction disc technology from SKF for turbine main shaft applications

There are several key benefits of SKF's friction disc technology. A significant increase of friction can result in cost savings through mass reduction, and maximizing torque flow, for example in flange couplings. The unique design is robust, virtually maintenance-free, reusable, and most importantly, very suitable for offshore and sub-sea environments.

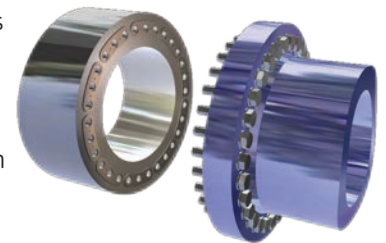

- (continued)

3 Gearbox: Improve performance with SKF high-capacity cylindrical roller bearings

Turbine gearboxes demand components that can provide high operational reliability and long service life. SKF high-capacity cylindrical roller bearings can help, as they combine the maximum load carrying capacity of a full complement bearing with the robust performance of a caged bearing. SKF high-capacity cylindrical roller bearings provide lower energy consumption and increased load carrying capacity versus standard caged bearings. They also offer extended maintenance intervals and lower noise and vibration levels.

Combining the advantages of conventional and SKF high-capacity cylindrical roller bearings, the SKF separable version can help bring gearbox reliability and safety to the next level. Their unique bearing design reduces the risk of smearing, adhesive wear and bearing failures on high-speed shafts, while allowing high-speed intermediate shafts to withstand higher loads. SKF's separable version of the high-capacity cylindrical roller bearing picks up where the non-separable high-capacity cylindrical roller bearing leaves off. These bearings can be mounted like standard cylindrical roller bearings, and the reduced roller drop even makes it easier.

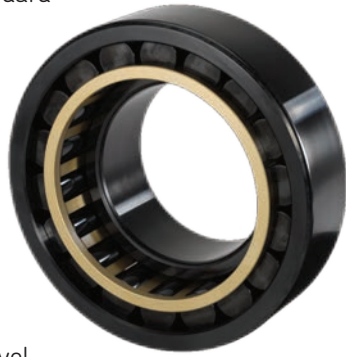

Black oxidation of rings and rollers

Black oxidation of rings and rollers improves reliability and performance in highly demanding applications, especially under low load conditions and vibration. In addition, it provides anti-corrosion protection and improves the lubricant adhesion on the surfaces. Therefore, it is highly recommended to use black oxidation for tapered roller bearings on the high speed shaft, and for cylindrical roller bearings in the planetary and parallel shaft stage.



4 Generator: Reduce the risk of damage from stray currents and improve performance

Unacceptable noise levels and electric current damage are two of the technical challenges common to generators.

SKF Quiet Running deep groove ball bearings

SKF can assist from design to operation with quiet running all-steel bearings that significantly reduce noise levels and minimize the structural resonance excitation of the system. Therefore they contribute to high reliability in generators.



SKF hybrid bearings

To prevent electric current from passing through the bearing, we recommend SKF hybrid bearings with rings made of bearing steel and rolling elements of silicon nitride, an electric insulating ceramic. Imagine being able to both increase turbine availability and reduce the cost of each kWh produced. SKF hybrid bearings can make it possible.



Tidal energy solutions (continued)

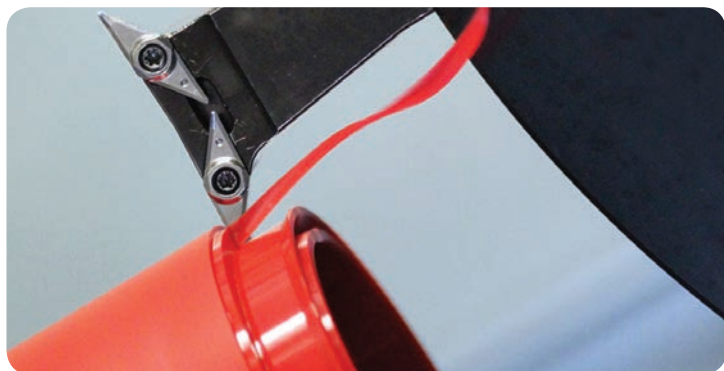

Sealing solutions: Reduce the risk of contaminating bearings and the ocean environment

Sealing solutions from SKF are designed to provide maximum protection against contaminants and seawater ingress while retaining the system lubricant. SKF works in close partnership with customers at the design phase to develop high-performance materials and seals that reliably operate in the harsh environment to which tidal stream energy converters are exposed.

With decades of experience in developing and manufacturing shaft seals for marine applications, SKF's engineers are able to develop customized solutions to operate in demanding conditions. The solutions include lip seals and face (mechanical) seals as well as combinations of both sealing technologies for extreme operating conditions.

SKF continuously develops its offerings and operates its own testing facilities around the world to provide optimized sealing solutions that meet sophisticated industry demands. Finite element analysis (FEA) is used to simulate the impact of operating conditions, material selection and seal design on seal behaviour.

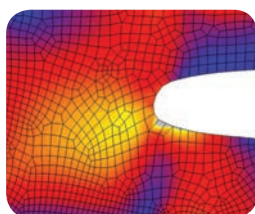

Effective maintenance

SKF lubrication systems provide tidal devices with the correct quantity of the appropriate lubricant at the right positions at the right time. From very simple to extremely complex, SKF lubrication systems help to ensure long-term reliability and availability. Through proper lubrication, critical components are protected and machinery life is extended.



Additionally, with SKF lubrication systems, environmental impact is minimized by avoiding over-greasing. SKF lubrication systems can be easily integrated with SKF condition monitoring systems to further simplify maintenance and enhance reliability. The combination allows operators a complete overview of the lubrication system.

Tools and grease: Reduce maintenance costs

Through extensive investigation, SKF has found that around 60% of premature bearing failures are attributed to poor fitting, inadequate lubrication and contamination. SKF offers a wide range of solutions to help reduce premature bearing failures and extend machine service life.

SKF provides a complete range of tools for the safe and easy mounting and dismounting of bearings and couplings, including lubricating and alignment equipment and bolt tensioners.

A comprehensive suite of training courses is available to help develop competence in areas such as mounting/dismounting, alignment, and lubrication, as well as correct use of the tools themselves.

Bolt tensioning tools and alignment services

Improper tools and processes to tighten bolts is a major cause of failure. To combat this problem SKF has developed a comprehensive range of hydraulic bolt tensioners that can be used anywhere to perform tightening operations in a reliable and repeatable manner. In addition, shaft misalignment is responsible for up to 50% of all costs related to rotating machinery breakdowns. SKF offers a comprehensive range of highly-skilled, onsite alignment services helping to ensure optimum machine efficiency and reliability.

Bearing remanufacturing: Improve sustainability and reduce costs

SKF has decades of expertise in bearing remanufacturing. All work is performed at our dedicated state-of-the-art remanufacturing service centres by specialists who comply with rigorous SKF specifications.

Bearing remanufacturing can result in savings of up to 50% of the cost of a new bearing and eliminate 80% of the CO₂ emissions resulting from the manufacture of a new bearing. In addition to bearings, SKF can also remanufacture housings.

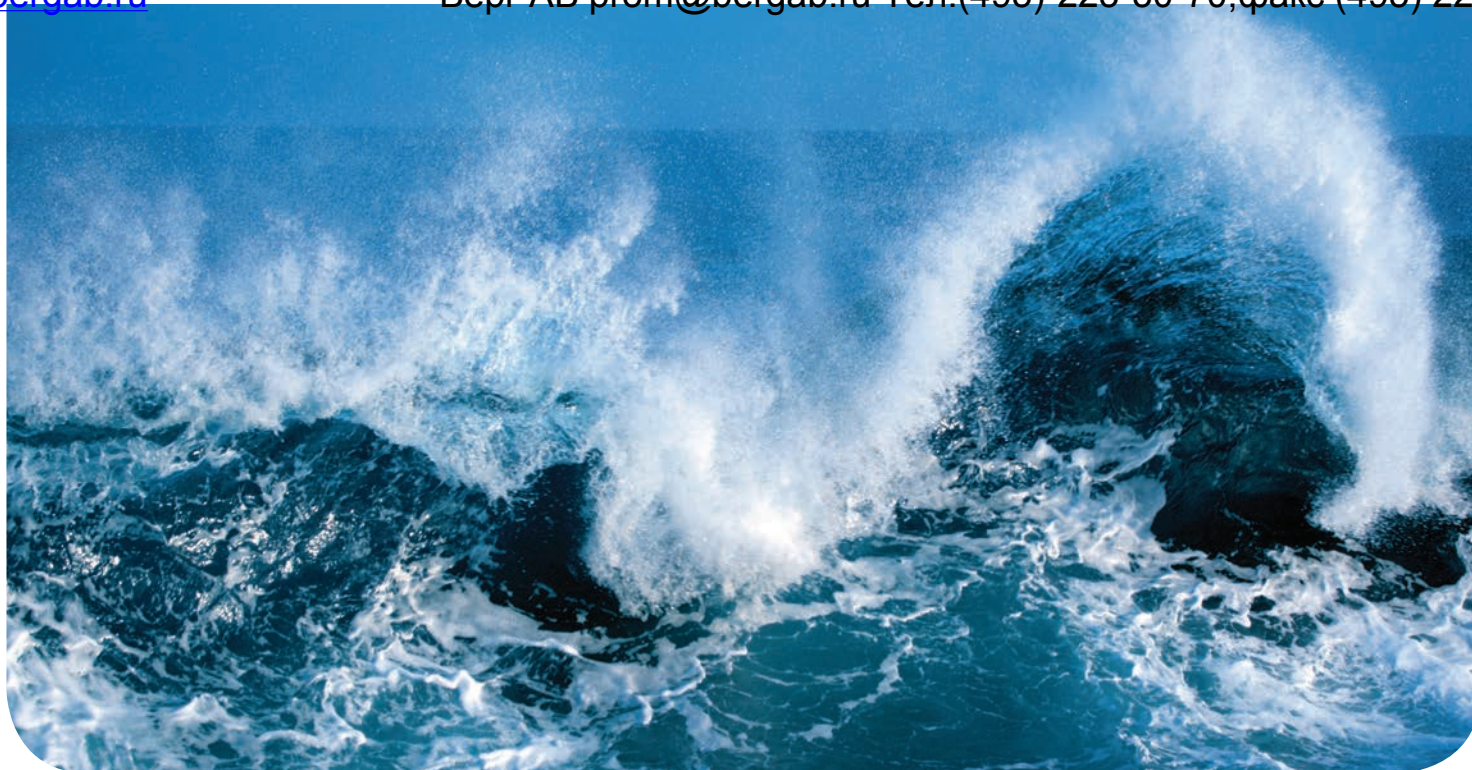

SKF solutions for wave energy sector

SKF solutions to convert wave motion to electricity

Special buoys, turbines, and other technologies convert the natural movement of ocean waves into clean, renewable electricity.

Regardless of the technology, SKF's knowledge can play a key role in system behaviour, with expertise in pumps, hydroelectric power plants, hydraulic cylinders, linear motion technologies and generators.

Spherical plain bearings, rod ends and bushings

Today, there is an increasing need to provide bearing solutions that will minimize maintenance and consume less lubricant while increasing bearing service life. To meet this challenge and future demands, SKF has developed TX spherical plain bearings and rod ends. In addition, SKF offers virtually maintenance-free and corrosion resistant filament wound bushings to reduce operating costs.

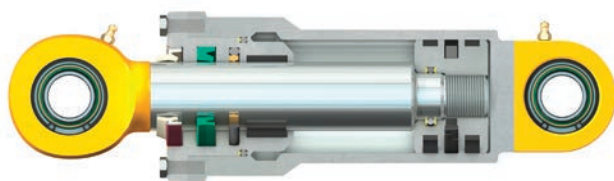

Hydraulic sealing solutions

The SKF standard assortment of hydraulic seals comprises hundreds of different designs and material combinations. In addition, SKF can offer customized sealing solutions to meet virtually any application requirements with its engineering expertise and flexible manufacturing system.

SKF actuation systems: Achieve higher energy yield compared to hydraulic systems

SKF electromechanical actuation systems are often used to replace hydraulics with the main benefits of increased performance and efficiency. They are robust and easily maintained and help reduce the environmental risks of hydraulic fluid contamination. Thanks to SKF high power density ball and roller screws, a wave device's hydraulic system can be eliminated and replaced with an SKF electromechanical actuation system.



Additional offers

In many cases, our tidal offerings have equal relevance to the wave energy sector, such as:

- Condition monitoring
- Lubrication systems
- SKF hybrid bearings
- SKF Quiet Running deep groove ball bearings
- Supergrip bolts
- Friction disc

In addition, we have the expertise and knowledge to customize existing solutions to create new innovative offerings addressing specific technical challenges in the wave sector.

SKF Engineering Consultancy Services

Our comprehensive services, which consist of powerful R&D tools and engineering processes, are available to ocean energy machine developers. SKF Engineering Consultancy Services helps developers extend their own in-house design engineering team capabilities and areas of specialized competencies.

Combined with our extensive application engineering knowledge and experience, our tools and processes are the same as those used to develop our own world-class products. SKF can help develop and select the best design concepts, optimize the design according to the specifications and reduce development time. We also help verify and test the design to reduce risks of failure and warranty costs.

A range of machine design services and expertise

By applying finite element method calculations, for example, we can help define bearing preload, fatigue life and bearing contact stresses during all load cases.

Using an SKF “virtual” test rig, we can simulate different operating conditions of multi-megawatt machines. These simulations can include testing different materials, operating temperatures of different positions and the results of lubricant starvation.

Should a machine or component fail under test or in service, SKF offers both root cause analysis (RCA) and root cause failure analysis (RCFA) services. Identifying and eliminating the root cause of a fault allows us to make recommendations to improve reliability, resulting in an increased mean time between failure (MTBF).

Getting it “right” at this early stage reduces capital expenditures (CAPEX), and results in a machine that is both maintainable and reliable in the operations phase. In the long-term, this improves availability, reduces total cost of ownership and cost of energy generation.

In short, SKF helps ensure that developer’s new machine designs are “right” from the start.



As one of the world’s leading global engineering solutions providers, SKF aims to work in partnership with the emerging ocean industry, adding value in the field of bearings, seals, lubrication systems, services and mechatronics. With over 100 years of acquired knowledge in rotating machinery across a wide range of sectors, SKF is uniquely positioned to be part of this exciting journey to success, from prototype testing through to large scale array deployment.

*See inserts for more details
about SKF solutions for the
ocean energy industry.*

The Power of Knowledge Engineering



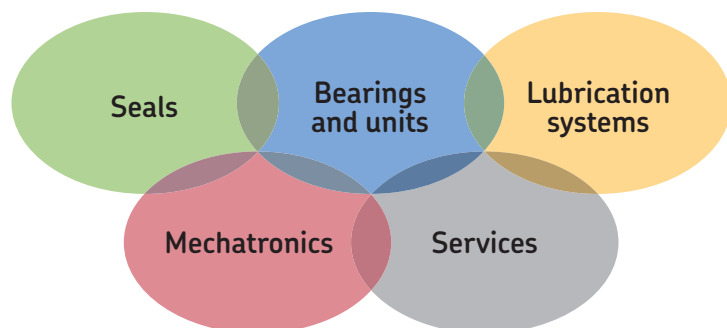

The Power of Knowledge Engineering

Drawing on five areas of competence and application-specific expertise amassed over more than 100 years, SKF brings innovative solutions to OEMs and production facilities in every major industry worldwide. These five competence areas include bearings and units, seals, lubrication systems, mechatronics (combining mechanics and electronics into intelligent systems), and a wide range of services, from 3-D computer modelling to advanced condition monitoring and reliability and asset management services. A global presence provides SKF customers uniform quality standards and worldwide product availability.

© SKF is a registered trademark of the SKF Group.

™ Nautilus is a trademark of the SKF Group

© SKF Group 2013

The contents of this publication are the copyright of the publisher and may not be reproduced (even extracts) unless prior written permission is granted. Every care has been taken to ensure the accuracy of the information contained in this publication but no liability can be accepted for any loss or damage whether direct, indirect or consequential arising out of the use of the information contained herein.

PUB 74/S2 13634 EN · April 2013

Printed in Sweden on environmentally friendly paper.

Certain image(s) used under license from Shutterstock.com

