

# SKF housings keep mining conveyors rolling longer with less maintenance

Combine SKF bearings with SKF housings for heavy-duty performance

**SKF housings are designed to accommodate the contamination, heavy loads and shock loads of the mining industry. Solutions include:**

- SNL and SAF housings accommodating inch and metric standards
- A wide range of SKF heavy-duty taconite seals for abrasive conditions
- SKF adapter and withdrawal sleeves for easy mounting with the oil injection method
- SKF mining specific (SMS) variant available for conveyors

## Compact and flexible

SKF housings' main purpose is to increase the life of bearings. They are designed on a "building block" principle that enables a wide choice of bearings, seals, mounting and lubrication methods for easy replacement of existing bearing arrangements.

## Less maintenance, friction and energy consumption

SKF housings have several built-in features that help reduce maintenance time and cost. SNL and SAF housings have two pre-drilled holes in the cap for re-lubrication, plus cast dimples to show where condition monitoring sensors can be mounted for maximum effectiveness.

SKF Taconite seal for better protection. Available as in-groove or bolt-on attachment.



## Benefits:

- Increase mean time between failures
- Reduce maintenance
- Facilitate lubrication
- Allow condition monitoring
- Reduce unplanned downtime
- Increase productivity

## Typical applications:

- Mining and port conveyors:
  - Head pulleys
  - Tail pulleys
  - Take-up pulleys
  - Bend pulleys

## SKF housing solutions for conveyors make SKF bearing arrangements easy to:

### Mount

To simplify mounting and make alignment more accurate out in the field, lines indicating the centre of the bore and the base are cast right into SKF housings. SKF adapter and withdrawal sleeves for oil injection enable bearings to be mounted hydraulically. This SKF-developed oil injection mounting method is intended to provide faster, safer and more secure mounting procedures. Oil-assisted sleeves also support easier dismounting.

### Seal

The number one reason for pulley bearing failure in mining is contamination due to inadequate sealing. A SKF Three-barrier solution can triple the mean time between failures (MTBF) to reduce downtime and maintenance. It combines:

- 1 A first barrier seal – either a labyrinth, lip-seal or a taconite seal
- 2 Free space between the seal and bearing filled with grease (possibly LGGB2)
- 3 A sealed spherical roller bearing

### Monitor

SKF SMS housing variants are designed to accommodate axial and radial vibration sensors – a particularly useful predictive maintenance approach for critical parts such as the drive end of the conveyor. All SKF systems use the envelope analysis, a signal processing technique that detects early signs of failure even at low rotational speeds.

### Maintain

SKF housings, including a SKF Three-barrier solution, increase uptime to the point that bearings outlast the conveyor lagging. The triple barrier is designed to avoid re-lubrication of the cavity between the seal or the seal itself – to give the ultimate protection.

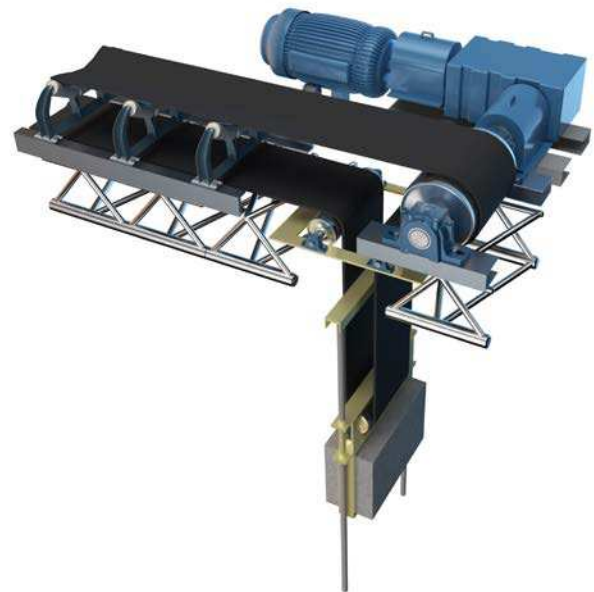

[skf.com](http://skf.com)

© SKF is a registered trademark of the SKF Group.

© SKF Group 2019  
The contents of this publication are the copyright of the publisher and may not be reproduced (even extracts) unless prior written permission is granted. Every care has been taken to ensure the accuracy of the information contained in this publication but no liability can be accepted for any loss or damage whether direct, indirect or consequential arising out of the use of the information contained herein.

PUB 73/S7 18257 EN · January 2019